

СЕРИЯ GMX

ОДНОСТУПЕНЧАТЫЕ ОТ 22 ДО 232 кВт / 1 stage from 22 up to 232 kW



газ/дизельное топливо - Gas/Light Oil



ОДНОСТУПЕНЧАТЫЕ 1 STAGE	kcal/h		kW		⚡
	min	max	min	max	
GM X 0	19.500	29.500	22,6	34,3	1F
GM X 1	25.000	60.000	29	69,8	
GM X 3	50.000	130.000	58,1	151	
GM X 4	100.000	200.000	116	232	

ТЕПЛОВОЙ РАСХОД / РАЗМЕРЫ (мм) - FIRING RATES / OVERALL DIMENSIONS (mm)

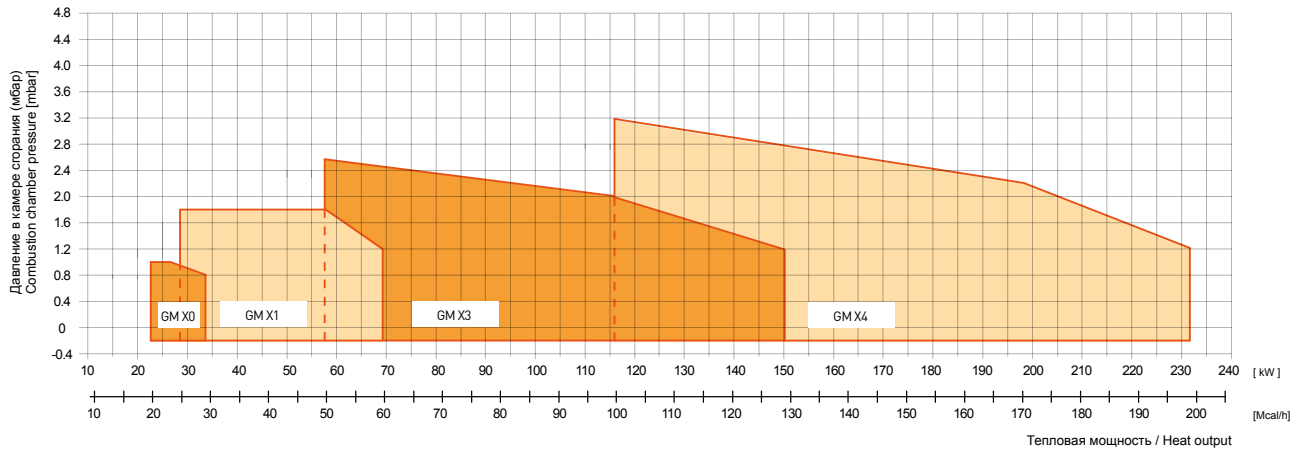
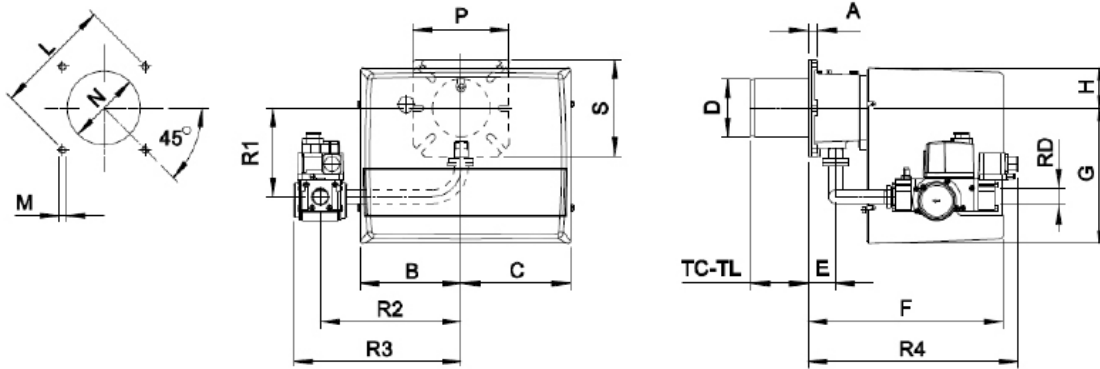

МОДЕЛЬ MODEL	*советовал/Suggested																							
	A	B	C	D	E	F	G	H	L min	L*	L max	M	N min	N*	N max	P	S	TC	TL	R1	R2	R3	R4	RD
GM X 0 - D1/2" - S	15	162	175	90	43	305	210	65	130	150	170	M8	100	110	130	150	150	90	150	132	200	254	240	1/2"
GM X 1 - D1/2" - S	15	162	175	90	43	305	210	65	130	150	170	M8	100	110	130	150	150	90	150	132	200	254	240	1/2"
GM X 1 - D3/4" - S	15	162	175	90	43	305	210	65	130	150	170	M8	100	110	130	150	150	90	150	138	220	262	328	3/4"
GM X 3 - D1" - S	16	185	195	108	54	340	248	70	150	170	170	M8	120	130	140	190	150	130	250	168	280	337	361	1"
GM X 4 - D1" - S	20	185	195	125	78	368	248	70	170	205	226	M10	130	140	160	200	200	160	280	173	280	337	385	1"